



INDUSTRIAL

Brad Point Boring Bits are coated with a non-stick coating for longer lasting cutting edge and tool life.

This special Polytetrafluoroethylene (PTFE) non-stick color coating is applied onto the bit at a temperature of 570° F. The coating reduces the friction between the chip and the body inside the flute and it helps to clear the chips out of the hole during the drilling, creating a cooler drilling area with no burning and a longer lasting cutting edge.

In cases where the carbide tip cutting edges are coated, there is no need to sand the coating off before use. Once the tool starts drilling, the coating is quickly cleared off the needed cutting edge.

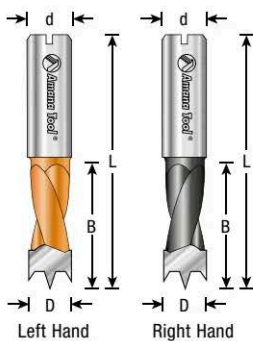

BRAD POINT BORING

Carbide Tipped • 57mm Long • 10mm x 30mm Shank*

ØD	B	Ød	L	Tool No.	
				LH	RH
3mm	27mm	10mm	57mm	301003†	201003†
3.2mm	27mm	10mm	57mm	301032†	201032†
4mm	27mm	10mm	57mm	301004	201004
4.5mm	27mm	10mm	57mm	—	201045
5mm	27mm	10mm	57mm	301005	201005
5.1mm	27mm	10mm	57mm	—	201051
5.2mm	27mm	10mm	57mm	301052	201052
5.5mm	27mm	10mm	57mm	301055	201055
6mm	27mm	10mm	57mm	301006	201006
6.5mm	27mm	10mm	57mm	—	201065
7mm	27mm	10mm	57mm	301070	201070
7.5mm	27mm	10mm	57mm	301075	201075
8mm	27mm	10mm	57mm	301008	201008
8.2mm	27mm	10mm	57mm	301082	201082
9mm	27mm	10mm	57mm	—	201090
10mm	27mm	10mm	57mm	301010	201010
10.5mm	27mm	10mm	57mm	301105	201105
12mm	27mm	10mm	57mm	301012	201012
14mm	27mm	10mm	57mm	301014	201014
15mm	27mm	10mm	57mm	301015	201015
17mm	27mm	10mm	57mm	301017	201017
19mm	27mm	10mm	57mm	—	201019
20mm	27mm	10mm	57mm	—	201020
1/4	27mm	10mm	57mm	301007	201007
3/8	27mm	10mm	57mm	301009	201009
1/2	27mm	10mm	57mm	301013	201013

† With solid carbide cutting edge.

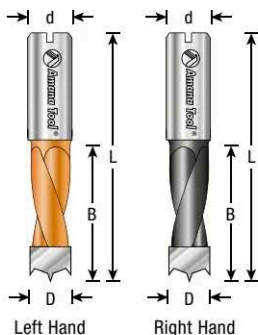
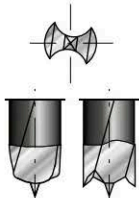

HIGH PERFORMANCE DITEC™ BRAD POINT BORING

Carbide Tipped • 57mm & 70mm Long • 10mm Shank*

Ditec™ dowel drills feature special grinding and high performance carbide for ultra long-lasting applications.

ØD	B	Ød	L	Tool No.	
				LH	RH
5mm	27mm	10mm	57mm	305005	205005
8mm	27mm	10mm	57mm	305008	—
5mm	40mm	10mm	70mm	306005	206005
8mm	40mm	10mm	70mm	306008	206008

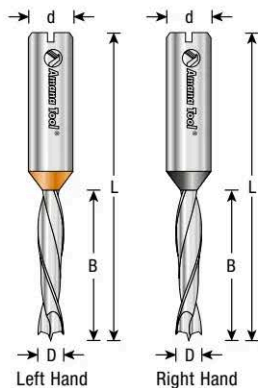

BRAD POINT DOWEL DRILL

Solid Carbide • 57.5mm & 70mm Long • 10mm x 30mm Shank*

Special solid carbide grade cutting flute for long lasting performance.

ØD	B	Ød	L	Tool No.	
				LH	RH
3mm	18mm	10mm	57.5mm	315103	215003
5mm	22mm	10mm	57.5mm	315105	215005
8mm	22mm	10mm	57.5mm	315108	215008
3mm	18mm	10mm	70mm	317003	217003
5mm	30mm	10mm	70mm	317005	217005
8mm	35mm	10mm	70mm	317008	217008

Max RPM=8,000

* Not to be used in portable drills or handheld routers.



BRAD POINT BORING

Carbide Tipped • 70mm Long • 10mm x 30mm Shank*

ØD	B	Ød	L	Tool No. LH	Tool No. RH
3mm	40mm	10mm	70mm	304003 †	204003 †
3.2mm	40mm	10mm	70mm	304032 †	204032 †
4mm	40mm	10mm	70mm	304004	204004
4.5mm	40mm	10mm	70mm	304045	204045
5mm	40mm	10mm	70mm	304005	204005
5.1mm	40mm	10mm	70mm	304051	204051
5.2mm	40mm	10mm	70mm	304052	204052
5.5mm	40mm	10mm	70mm	304055	204055
6mm	40mm	10mm	70mm	304006	204006
6.5mm	40mm	10mm	70mm	304065	204065
6.7mm	40mm	10mm	70mm	—	204067
7mm	40mm	10mm	70mm	304070	204070
7.5mm	40mm	10mm	70mm	304075	204075
8mm	40mm	10mm	70mm	304008	204008
8.2mm	40mm	10mm	70mm	304082	204082
9mm	40mm	10mm	70mm	304090	204090
10mm	40mm	10mm	70mm	304100	204010
11mm	40mm	10mm	70mm	304011	204011
12mm	40mm	10mm	70mm	304012	204012
13mm	40mm	10mm	70mm	304130	204130
14mm	40mm	10mm	70mm	—	204014
15mm	40mm	10mm	70mm	304015	204015
16mm	40mm	10mm	70mm	—	204016
17mm	40mm	10mm	70mm	304017	—
3/16	40mm	10mm	70mm	304047	204047
1/4	40mm	10mm	70mm	304007	204007
3/8	40mm	10mm	70mm	304009	204009
7/16	40mm	10mm	70mm	304111	204111
1/2	40mm	10mm	70mm	304013	204013
5/8	40mm	10mm	70mm	—	204113



77mm Long • 10mm x 30mm Shank*

4mm	47mm	10mm	77mm	302004	202004
5mm	47mm	10mm	77mm	302005	202005
5.1mm	47mm	10mm	77mm	302051	—
5.2mm	47mm	10mm	77mm	—	202052
7mm	47mm	10mm	77mm	—	202070
8mm	47mm	10mm	77mm	302008	202008
8.2mm	47mm	10mm	77mm	302082	202082
9mm	47mm	10mm	77mm	302090	—
10mm	47mm	10mm	77mm	—	202010
12mm	47mm	10mm	77mm	302012	202012

† With solid carbide cutting edge.

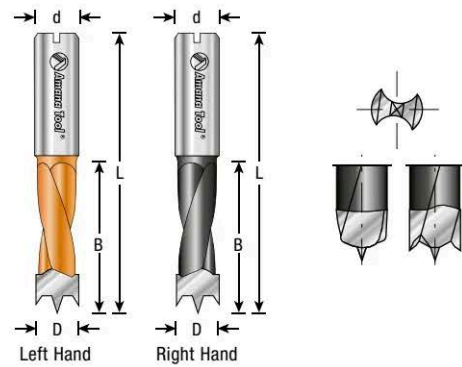

Max RPM=8,000

* Not to be used in portable drills or handheld routers.

INDUSTRIAL BORING BITS



INDUSTRIAL

Through-Hole with V-Point Boring Bits are coated with a non-stick coating for longer lasting cutting edge and tool life.

Amana Tool® dowel drills are coated with a special Polytetrafluoroethylene (PTFE), a non-stick color coating. In cases where the carbide tip cutting edges are coated, there is no need to sand the coating off before use. Once the tool starts drilling, the coating is quickly cleared off the needed cutting edge.

Amana's coating is applied onto the bit at a temperature of 570° F. The coating reduces the friction between the chip and the body inside the flute and it helps to clear the chips out of the hole during the drilling, creating a cooler drilling area with no burning and a longer lasting cutting edge.

THROUGH-HOLE WITH V-POINT

Carbide Tipped • 57mm Long • 10mm x 22mm Shank*

ØD	B	Ød	L	Tool No.	
				LH	RH
4mm	35mm	10mm	57mm	413004	313004
5mm	35mm	10mm	57mm	413005	313005
6mm	35mm	10mm	57mm	413006	313006
7mm	35mm	10mm	57mm	413070	313070
8mm	35mm	10mm	57mm	413008	313008
9mm	35mm	10mm	57mm	413090	—
10mm	35mm	10mm	57mm	413010	313010
12mm	35mm	10mm	57mm	413012	—
1/4	35mm	10mm	57mm	413007	—
3/8	35mm	10mm	57mm	413009	313009
1/2	35mm	10mm	57mm	413013	—

THROUGH-HOLE WITH V-POINT

Carbide Tipped • 70mm Long • 10mm x 23mm Shank*

ØD	B	Ød	L	Tool No.	
				LH	RH
4mm	47mm	10mm	70mm	414004	314004
5mm	47mm	10mm	70mm	414005	314005
5.5mm	47mm	10mm	70mm	414055	314055
6mm	47mm	10mm	70mm	414006	314006
7mm	47mm	10mm	70mm	414070	314070
8mm	47mm	10mm	70mm	414008	314008
9mm	47mm	10mm	70mm	414090	314090
10mm	47mm	10mm	70mm	414010	314010
11mm	47mm	10mm	70mm	—	314011
12mm	47mm	10mm	70mm	414012	314012
14mm	47mm	10mm	70mm	414014	—
3/16	47mm	10mm	70mm	414047	314047
1/4	47mm	10mm	70mm	414007	314007
9/32	47mm	10mm	70mm	414281	314281
21/64	47mm	10mm	70mm	414833	314833
11/32	47mm	10mm	70mm	414343	—
3/8	47mm	10mm	70mm	414009	314009
7/16	47mm	10mm	70mm	414111	314111
1/2	47mm	10mm	70mm	414013	314013
5/8	47mm	10mm	70mm	—	314113

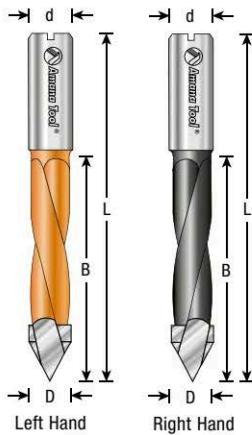

Max RPM=8,000

* Not to be used in portable drills or handheld routers.



THROUGH-HOLE WITH V-POINT

Carbide Tipped • 77mm Long • 10mm x 27mm Shank*

ØD	B	Ød	L	Tool No. LH	Tool No. RH
5mm	50mm	10mm	77mm	415005	315005
7mm	50mm	10mm	77mm	—	315070
8mm	50mm	10mm	77mm	415008	315008

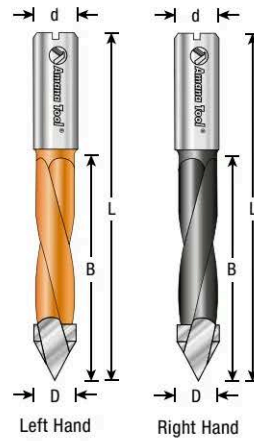

THROUGH-HOLE DOWEL DRILL

Solid Carbide • 70mm Long • 10mm x 30mm Shank*

Special solid carbide grade cutting flute for long lasting performance.



ØD	B	Ød	L	Tool No. LH	Tool No. RH
3mm	18mm	10mm	70mm	317013	217013
5mm	30mm	10mm	70mm	317015	217015
8mm	35mm	10mm	70mm	317018	217018

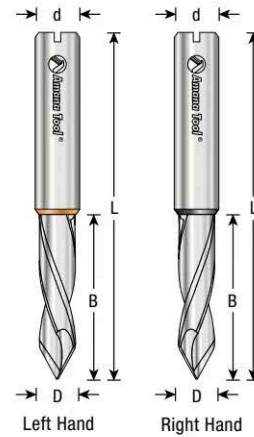

DOWEL DRILL/BORING BIT ADAPTER

For CNC Standard Collet/Tool Holder

Made especially to run 10mm shank dowel drills and boring bits on a CNC machine. Accommodates the flat area on the 10mm round drill bit shank. Secure with the two set screws, same method as on boring machines.

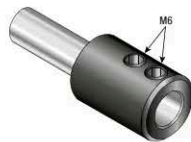

ØD1	Ød	ØD	L	L1	Tool No.
10mm	6mm	3/4	2-5/32	1-1/16	47643
10mm	1/4	3/4	2-5/32	1-1/16	47636
10mm	10mm	3/4	2-5/32	1-1/16	47644
10mm	1/2	3/4	2-7/16	1-1/16	47638

▲ Warning: Maximum RPM=8,000

Total Indicated Run-out (TIR) is 0.00118" (0.03mm)
CNC drop down feed rate 80-160 inches per minute (IPM).

Max RPM=8,000

* Not to be used in portable drills or handheld routers.

INDUSTRIAL BORING BITS



COUNTERSINKS FOR BORING MACHINES*

Carbide Tipped • Slow Spiral, HSS M2 DIN 338 Fully Ground Drill

Drills and countersinks in one step. Available in two sizes and each complete with the High Speed Steel drill bit and Allen wrench for easy bit replacement. 2-Flute.



ØD	ØD1	a°	Ød	L	Repl. Drill Bit	Tool No.
1/2	4mm	45°	10mm	60mm	630-202	55640
1/2	5mm	45°	10mm	60mm	55105	55642



METRIC COUNTERSINKS*

Carbide Tipped • 2 Flute

Application: Use with 10mm shank boring bits to drill and countersink for screws in one pass.

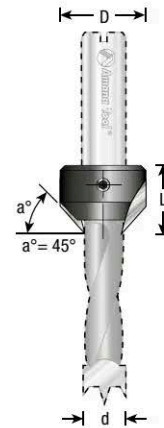

ØD	Ød	L	Tool No. LH	Tool No. RH
16mm	5mm	16.5mm	416005	316005
16mm	7mm	16.5mm	416007	316007
18mm	8mm	16.5mm	416008	316008
18mm	9mm	16.5mm	—	316009
20mm	12mm	16.5mm	416012	316012

Replacement set screw #67087 (5mm only).

Replacement set screw #67079 (6mm to 12mm).

Note: Right hand tools rotate clockwise. Left hand tools rotate counter-clockwise.

Drills sold separately.

* Not to be used in portable drills or handheld routers.

HINGE BORING

*Carbide Tipped • 57mm Long • 10mm Shank • 2-Wing with Spurs**

Application: Boring machines (10mm shank) and drill presses (3/8" shank)

ØD	Ød	L	Tool No.	
			LH	RH
15mm	10mm	57mm	203155	203151
20mm	10mm	57mm	203205	203201
22mm	10mm	57mm	—	203221
25mm	10mm	57mm	—	203251
26mm	10mm	57mm	—	203261
28mm	10mm	57mm	203285	—
30mm	10mm	57mm	203305	—
35mm	10mm	57mm	203355	203351
40mm	10mm	57mm	—	203401
3/4	10mm	57mm	—	203751

*70mm Long • 10mm Shank • 2-Wing with Spurs**

15mm	10mm	70mm	—	203152
20mm	10mm	70mm	203204	203202
25mm	10mm	70mm	203254	203252
26mm	10mm	70mm	203264	203262
35mm	10mm	70mm	203354	203352
3/4	10mm	70mm	203754	203752

*77mm Long • 10mm Shank • 2-Wing with Spurs**

25mm	10mm	77mm	203258	—
30mm	10mm	77mm	203308	—

*90mm Long • 2-Wing with Spurs**

28mm	10mm	90mm	—	203286
35mm	10mm	90mm	—	203357



BITS FOR FESTOOL® DOMINO® JOINER

*Solid Carbide & Carbide Tipped • 2 Flute • Right Hand Rotation**

Application: Used on Domino® machines for routing slots on solid wood and wood composites.

ØD	B	Thread (Inside Shank)	L	For Festool® No.	Tool No.
4mm	11mm	M6x0.75	38mm	DF500	316020†
5mm	20mm	M6x0.75	49mm	DF500	316022
6mm	28mm	M6x0.75	49mm	DF500	316024
8mm	28mm	M6x0.75	49mm	DF500	316026
8mm	50mm	M8x1	90mm	DF700	316028
10mm	28mm	M6x0.75	49mm	DF500	316030
10mm	70mm	M8x1	90mm	DF700	316032†
12mm	70mm	M8x1	90mm	DF700	316034†
14mm	70mm	M8x1	90mm	DF700	316036†

† Solid carbide.

* Not to be used in portable drills or handheld routers.

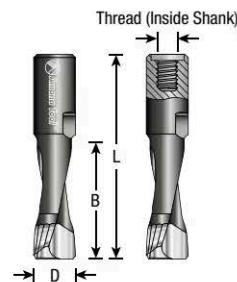

INDUSTRIAL BORING BITS

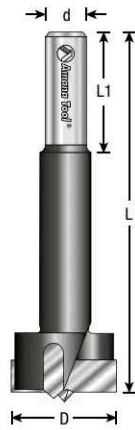

HINGE BORING*

Carbide Tipped • 10mm Round Shank • 2-Wing With Spurs

Application: Drill presses only / Metric European hinges.

ØD	Ød	L1	L	Tool No.
15mm	10mm	30mm	90mm	203015
20mm	10mm	30mm	90mm	203020
23mm	10mm	30mm	90mm	203023
35mm	10mm	30mm	90mm	203350
40mm	10mm	30mm	90mm	203040

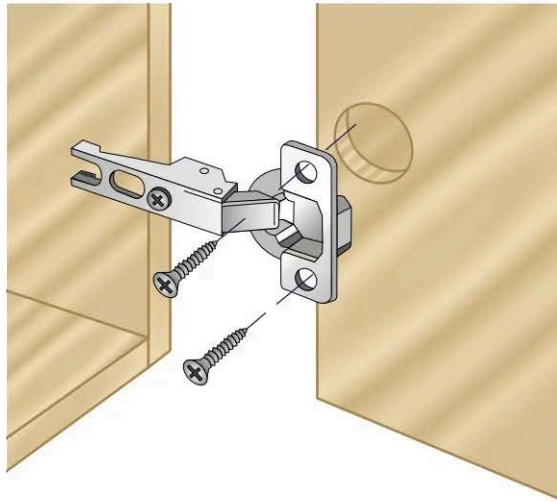

Boring bit sold separately.

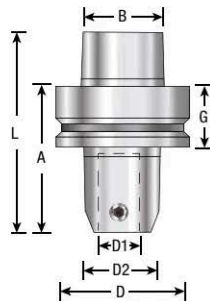

CNC DRILL CHUCK New

HSK Drill Chuck

CNC Boring and drilling chuck designed to clamp Boring and drills bits with 10mm shank.

- for RH or LH rotation tools
- HSK63F chuck with a maximum error of concentricity between the cone and the tool seat of 0.003mm.

ØD	Adapter Standard	B	D1	D2	G	A	L	Tool No.
63mm(2-15/32)	HSK63F	38mm	10mm	34mm	26mm	65mm	90mm	HO-190

3-PC. BRAD POINT & HINGE BORING BIT SET*

Carbide Tipped • 57 Long x 10mm Shank

Complete hinge installation set for boring machines.

Set# HBM-102 contains:

ØD	B	Ød	L	Type	Qty.	Tool No.
8mm	27mm	10mm	57mm	Brad Point Boring	2	301008
35mm	—	10mm	57mm	Hinge Boring	1	203351
3-Pc. Set includes 301008(2) and 203351(1)						HBM-102



Set# HBM-102



* Not to be used in portable drills or handheld routers.

HINGE BORING

*Carbide Tipped • 2-Wing with Spurs with Adjustable Depth Stop
Quick Release 1/4" Hex Shank*

Carbide tipped with center point. Adjustable aluminum depth-stop that allow to control the depth of blind holes. Depth Range 3/8" (9.52mm) to 1/2" (12.7mm).

Prevents from damaging the door. Simple depth control.

ØD	ØD1	A	Ød	L	Wings	Tool No.
35mm	1-21/32	3/8 (9.52mm) - 1/2 (12.7mm)	1/4	2-3/8	2	203361

Replacement drill bit #55289.

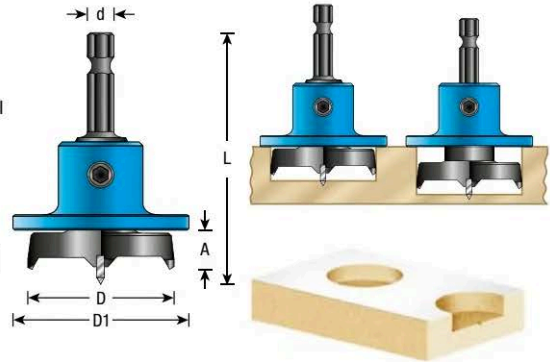

HINGE BORING FOR DRILL PRESSES*

Carbide Tipped • 3/8" Shank • 2-Wing

Application: Drill presses only, right hand rotation. Economical alternative to other 35mm hinge bits.

ØD	Ød	L	Tool No.
35mm	3/8	57mm	EB-351

Note: Right hand tools rotate clockwise. Left hand tools rotate counter-clockwise.



HINGE BORING FOR ROUTERS

*Carbide Tipped • 60mm Long, 1/2 Shank, 2-Wing (No Spurs)**

Application: Designed for high RPM (22,000) on plunge routers, CNC routers, machining centers and point-to-point machines.

ØD	Ød	L1	L	Max RPM	Tool No.
35mm	1/2	30mm	60mm	28,000	203431

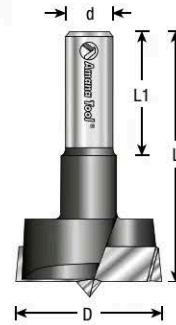

FRACTIONAL SIZE BORING*

Carbide Tipped • 2-Wing • With Spurs

Application: 1/2" shank for use in drill presses only.

ØD	Ød	L	Wings	Tool No.
1-1/8	1/2	4	2	420208
1-1/4	1/2	4	2	420308
1-1/2	1/2	4	2	420508



* Not to be used in portable drills or handheld routers.

INDUSTRIAL BORING BITS

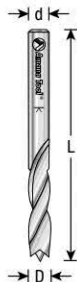

METRIC BRAD POINT BORING DRILLS*

Solid Carbide

Application: Boring machines for shelving hardware, etc. Use with adapters or bushings, shown below.

$\emptyset d$ & $\emptyset D$	L	Tool No. LH	Tool No. RH
3mm	55mm	463003	363003
3.2mm	55mm	463032	363032
3.5mm	55mm	463035	363035
4mm	55mm	463004	—
4.5mm	55mm	463045	—
5mm	55mm	—	363005

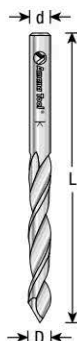

METRIC V-POINT BORING DRILLS*

Solid Carbide • 60°

Application: Boring machines for shelving hardware, etc. Use with adapters or bushings, shown below.

$\emptyset d$ & $\emptyset D$	L	Tool No. LH	Tool No. RH
2mm	49mm	463002	363002
2.5mm	55mm	463025	363025
5mm	55mm	—	363007

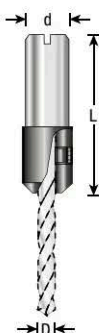

10MM SHANK DRILL ADAPTERS*

With Retaining Screw

Application: Use with solid carbide drills, shown above. For quick insertion and removal from chuck. (Can be used on left or right hand drills.)

Drills sold separately.

$\emptyset D$	$\emptyset d$	L	Tool No.
2mm	10mm	38mm	364020
2.3mm	10mm	38mm	364023
2.5mm	10mm	38mm	364025
3mm	10mm	38mm	364030
3.2mm	10mm	38mm	364032
3.5mm	10mm	38mm	364035
4mm	10mm	38mm	364040
1/4	10mm	38mm	364063

Replacement set screw #67092 (new style #10-24) or #67097 (old style 5x8mm).



10MM SHANK DRILL BUSHINGS*

Application: Use with solid carbide drills, shown above. Economical alternative to drill adapters. (Can be used on left or right hand drills.)

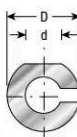

$\emptyset d$	$\emptyset D$	L	Tool No.
2mm	10mm	23mm	365020
2.5mm	10mm	23mm	365025
3mm	10mm	23mm	365030
3.2mm	10mm	23mm	365032
3.5mm	10mm	23mm	365035
4.5mm	10mm	23mm	365045
5mm	10mm	23mm	365050
6.0mm	10mm	23mm	365054
7.0mm	10mm	23mm	365056
8.0mm	10mm	23mm	365058



* Not to be used in portable drills or handheld routers.

HIGH SPEED STEEL (HSS) PLASTIC DRILLS

High Speed Steel (HSS) • 5 Pc. Packs

Drills designed to drill holes in hard and soft plastic. 60° drill tip.

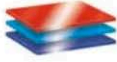

Excellent For Drilling:

- Acrylic
- Acrylite®
- Lucite®
- Plexiglas®
- Hard and Soft Plastic

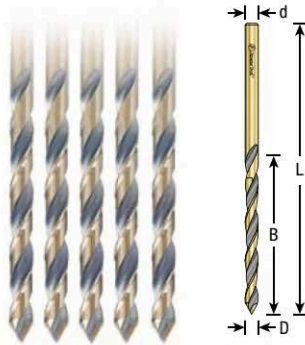

ØD & Ød	B	L	Per Pack	Tool No.
1/8	1-1/2	2-3/4	5	HSS1520
3/16	2-1/8	3-1/2	5	HSS1522
1/4	2-7/16	4	5	HSS1524

HIGH SPEED STEEL (HSS) M2 DIN 338 FULLY GROUND STEP DRILLS

HSS • Slow Spiral

ØD	B	Ød	L	Tool No.
3/32	5/8	9/64	2-3/4	630-010
7/64	3/4	5/32	3	630-012
1/8	7/8	11/64	3-1/8	630-014
9/64	1	3/16	3-3/8	630-016

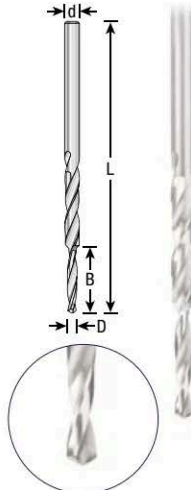

HIGH SPEED STEEL (HSS) M2 DIN 338 FULLY GROUND DRILLS

HSS • Taper Point

ØD & Ød	B	L	Tool No.
5/64	15/16	2-1/8	630-260
3/32	1-1/8	2-1/4	630-262
7/64	1-3/8	2-11/16	630-264
1/8	1-1/2	2-3/4	630-266
9/64	1-1/16	2-15/16	630-268
5/32	1-3/4	3-1/8	630-270
11/64	1-15/16	3-1/4	630-272
3/16	2	3-9/16	630-274
7/32	2-1/4	3-13/16	630-276
1/4	2-7/16	4	630-278

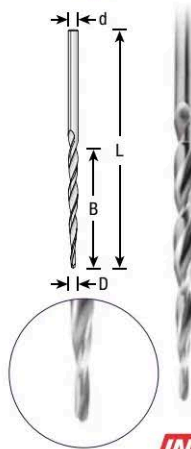

HIGH SPEED STEEL (HSS) M2 DIN 338 FULLY GROUND DRILLS

HSS • Regular Flute

ØD & Ød	B	L	Tool No.
5/64	13/16	1-15/16	630-220
3/32	1	2-1/4	630-222

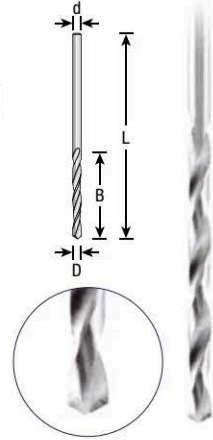

HIGH SPEED STEEL (HSS) M2 DIN 1897 FULLY GROUND SHORT DRILLS

HSS • Regular Flute

ØD & Ød	B	L	Tool No.
7/64	1/2	1-3/4	630-224
1/8	9/16	2	630-226
9/64	11/16	2-1/16	630-228
5/32	11/16	2-1/8	630-230
11/64	3/4	2-5/16	630-234
3/16	3/4	2-1/4	630-236

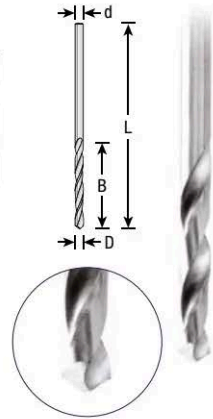

HIGH SPEED STEEL (HSS) DIN 338 FULLY GROUND DRILLS

HSS • Slow Spiral

ØD & Ød	B	L	Tool No.
5/64	7/8	1-15/16	630-001
3/32	1	2-1/4	630-002
7/64	1-1/8	2-3/8	630-098
1/8	1-3/16	2-9/16	630-102
9/64	1-1/4	2-3/4	630-802
5/32	1-3/8	3	630-202
11/64	1-3/8	2-15/16	630-302
3/16	1-3/8	2-15/16	630-402
7/32	1-3/8	2-15/16	630-502
15/64	1	2-15/16	630-602
1/4	1-1/4	2-15/16	630-702
5/16	2-3/8	4-5/8	630-704
3/8	2-1/2	4-15/16	630-706
1/2	3-1/2	5-15/16	630-708

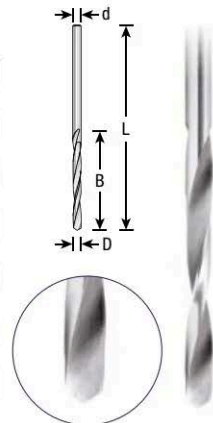



BORING MACHINE REPLACEMENT CHUCKS*

For 10mm Shank In-Line Boring Machines

Application: Replace worn or damaged chucks. In stock for immediate delivery. Meets or exceeds O.E.M. specifications.

Due to many different styles, please order carefully.

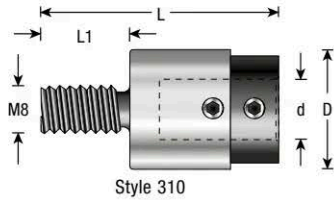

Chuck for Nottmeyer Machines

ØD	L1	M	Ød	L	Tool No.	
					LH	RH
19.5mm	15mm	8mm	10mm	40mm	310105	310010

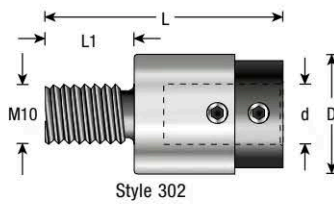

Chuck for Torwegge • Ayen Machines

ØD	L1	M	Ød	L	Tool No.	
					LH	RH
19.5mm	15mm	10mm	10mm	40mm	302105	302010

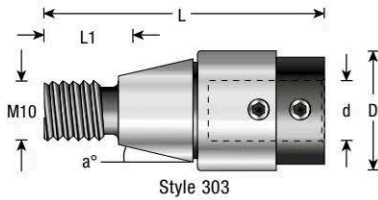

Chuck for Busselatto • Ompec Machines

ØD	L1	a°	M	Ød	L	Tool No.	
						LH	RH
19.5mm	11mm	30°	10mm	10mm	46mm	303105	303010

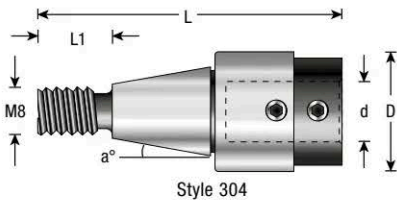

Chuck for Bilek Machines

ØD	L1	a°	M	Ød	L	Tool No.	
						LH	RH
19.3mm	11mm	20.8°	8mm	10mm	48mm	304105	304010

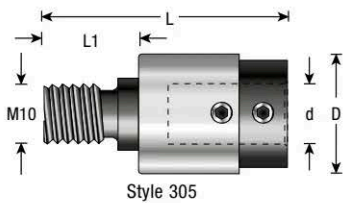

Chuck for Holz-Her • S.C.M.I. • Morbidelli • Biese Reimall • Vitap • Weeke Machines

ØD	L1	M	Ød	L	Tool No.	
					LH	RH
19.5mm	16mm	10mm	10mm	41mm	305105	305010

BORING MACHINE REPLACEMENT CHUCKS (CONT'D)

Chuck for • Morbidelli • Nottmeyer Machines

ØD	L1	M	Ød	L	Tool No.	
					LH	RH
19.3mm	15mm	8mm	10mm	41mm	—	358010



Chuck for Scheer Machines

ØD	M	Ød	L	Tool No.	
				LH	RH
19.5mm	10mm	10mm	42mm	359105	—

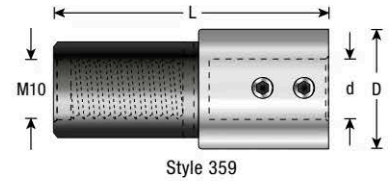

Note: Right hand tools rotate clockwise. Left hand tools rotate counter-clockwise.
1.5mm thread pitch.
Set screw #67097.

ROSETTE CUTTERS

Carbide Tipped • 2 Flute • 3/8" Shank • For Drill Press

ØD	ØD1	B	Ød	L	Max RPM	Tool No.
1-25/32	1-23/32	19/64	3/8	2-7/8	1,800	DP-300
2-1/2	2-27/64	25/64	3/8	2-7/8	1,800	DP-302
3-11/32	3-1/8	21/64	3/8	2-7/8	1,800	DP-304

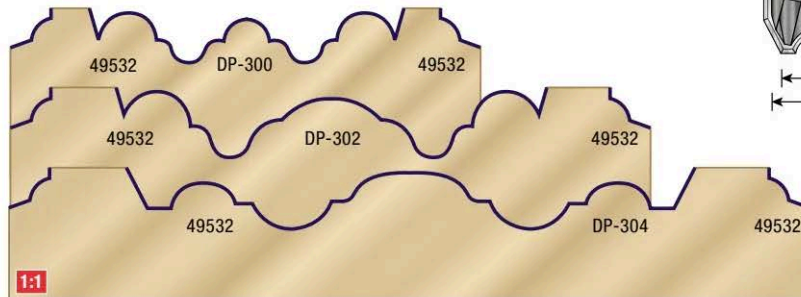
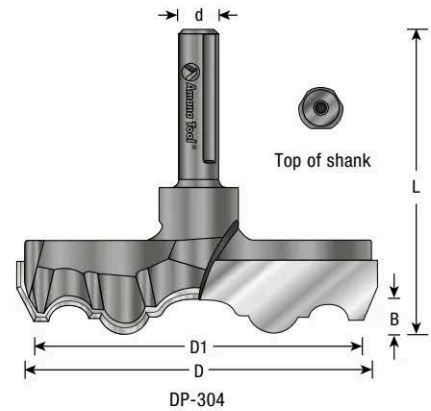

OPTIONAL ROSETTE EDGE DETAIL ROUTER BIT

Carbide Tipped • 2 Flute

Create the edge detail to the rosette to achieve the finished look.

ØD	a°	R	B	Ød	L	Tool No.
15/16	20°	9/64	1/4	1/4	1-5/8	49532

Replacement bearing #47706.

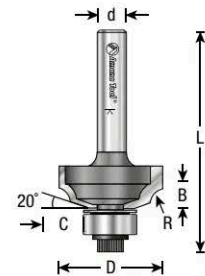

Optional Edge
Made With Tool #49532

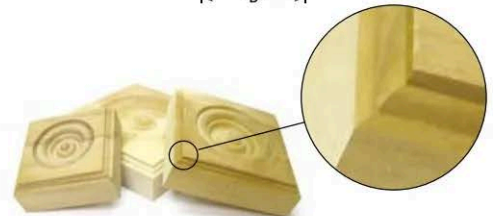

INDUSTRIAL BORING BITS